

LEFT VIEW SECTION A-A  
(LEFT HAND WINDOW)

FRONT VIEW  
(LEFT HAND WINDOW)

RIGHT VIEW  
(LEFT HAND WINDOW)

BOTTOM VIEW  
(LEFT HAND WINDOW)

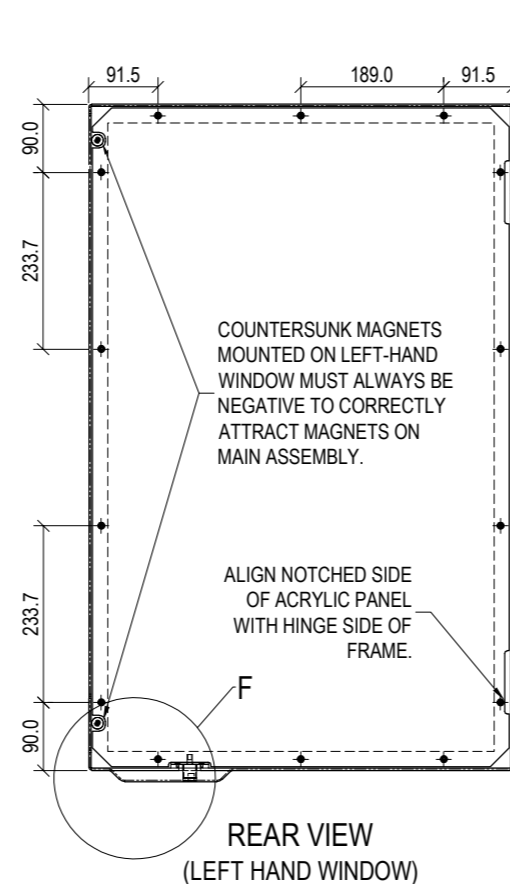

REAR VIEW  
(LEFT HAND WINDOW)

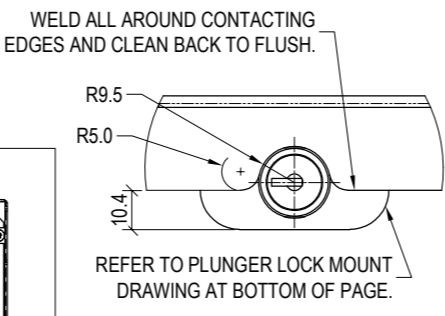

DETAIL G  
SCALE 1:2

PLUNGER LOCK MOUNT  
10mm STEEL BLOCK  
SCALE 1:2

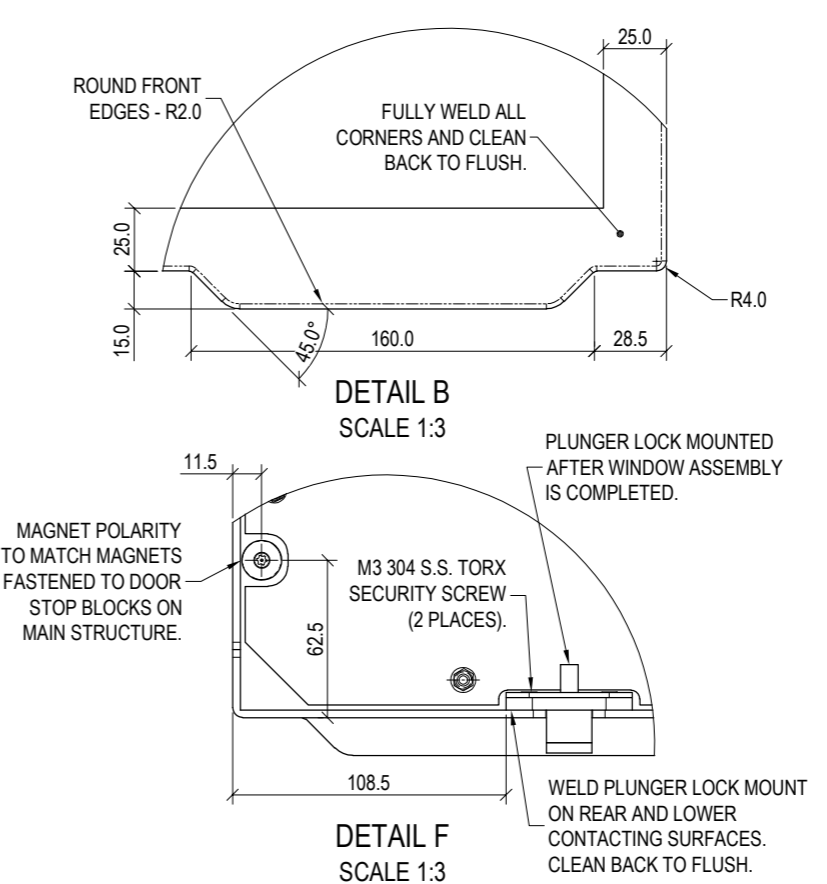

DETAIL B  
SCALE 1:3

DETAIL F  
SCALE 1:3

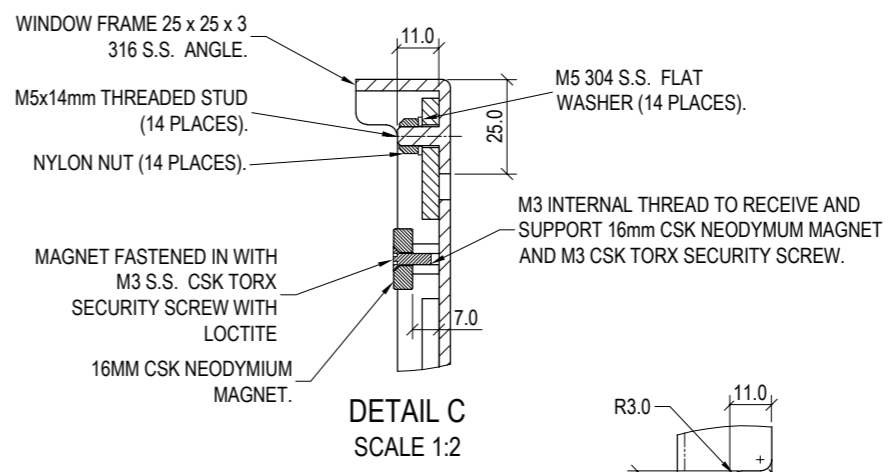

DETAIL C  
SCALE 1:2

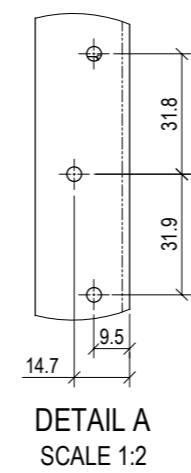

DETAIL A  
SCALE 1:2

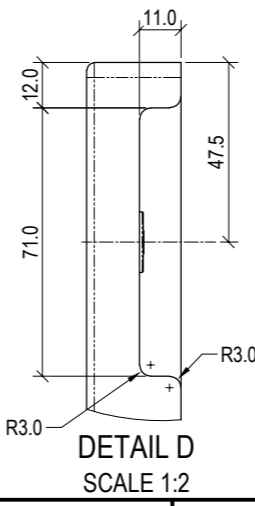

DETAIL D  
SCALE 1:2

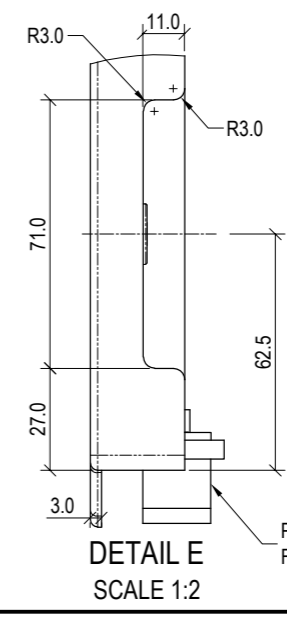

DETAIL E  
SCALE 1:2

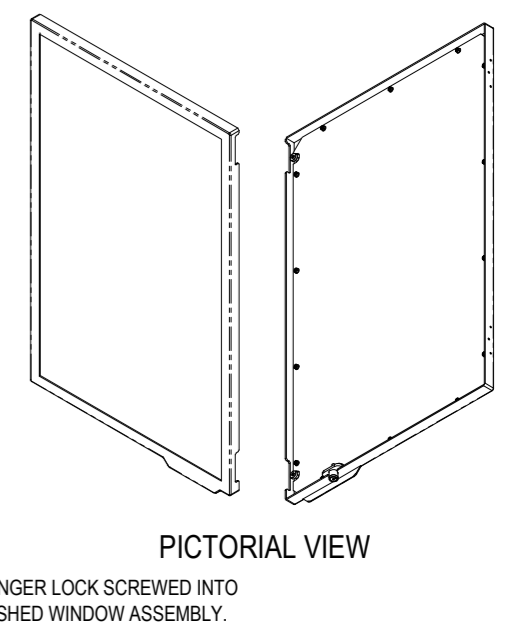

PICTORIAL VIEW

### STANDARDS

- DESIGNED IN ACCORDANCE WITH AND FABRICATED TO MEET THE FOLLOWING STANDARDS:
1. GUIDE TO ENGINEERING PRACTICE, 'PEDESTRIANS', PART 13, AUSTRROADS.
  2. AS1627.4 METAL FINISHING -PREPARATION AND PRE-TREATMENT OF SURFACES - ABRASIVE BLAST CLEANING OF STEEL.
  3. AUSTRALIAN ROAD RULES, 1999, WWW.NRTC.GOV.AU

### NOTES

1. WELDING TO BE IN ACCORDANCE WITH AS1554.1 CAT GP WELDING, ALL SHARP EDGES & BURRS REMOVED.
2. PART SHOULD BE SUPPLIED CLEAN AND FREE FROM MARKS, BURRS, SCUFFS, DISTORTION AND WARPAGE.
3. DRAWING TO AS1100 DRAWING STANDARDS.
4. REFER TO DRAWING BSD-7141 SHEET 7 FOR INSTALLATION DETAILS.
5. ALL TOLERANCES  $\pm 1.5\text{mm}$  UNLESS OTHERWISE SPECIFIED.

### MATERIAL

1. MATERIAL: 316 STAINLESS STEEL
2. COLOUR: NATURAL
3. FINISH: GARNET BLASTED

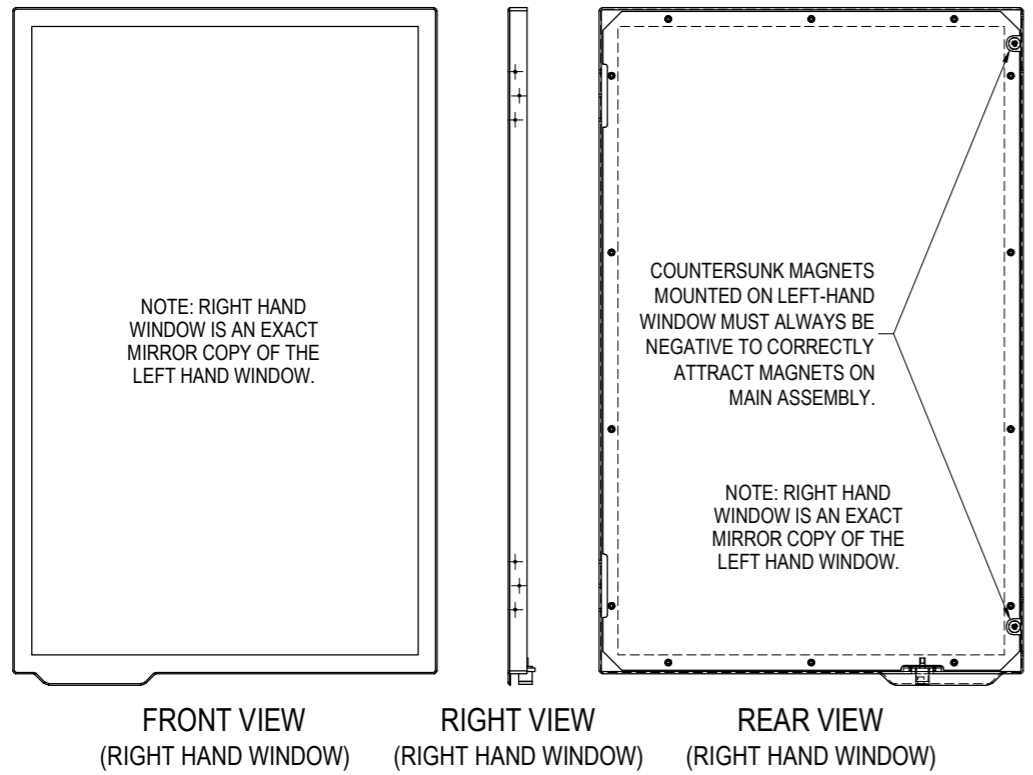

FRONT VIEW  
(RIGHT HAND WINDOW)

RIGHT VIEW  
(RIGHT HAND WINDOW)

REAR VIEW  
(RIGHT HAND WINDOW)

	<b>BRISBANE CITY COUNCIL STANDARD DRAWING</b>		PUBLISH DATE
	COMMUNITY NOTICE BOARD		SCALE
	WINDOWS		1:10
	SHEET 4 OF 8		DRAWING NUMBER
		<b>BSD-7141</b>	REVISION
		A3	A