

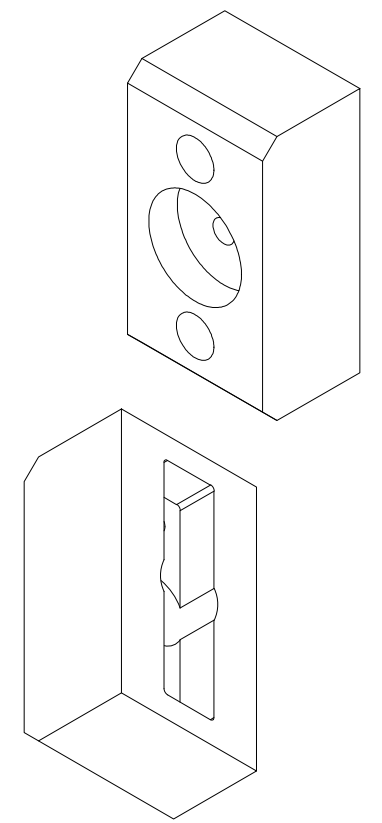

- NOTES**
- PART SHOULD BE SUPPLIED CLEAN AND FREE FROM MARKS, BURRS, SCUFFS, DISTORTION AND WARPAGE.
 - DRAWING TO AS1100 DRAWING STANDARDS.
 - ALL TOLERANCES $\pm 0.2\text{mm}$ UNLESS OTHERWISE SPECIFIED.
- MATERIAL**
- MATERIAL: ACETAL (POM)
 - COLOUR: BLACK
 - FINISH: SMOOTH MACHINE FINISH

ASSEMBLY NOTES AND DETAILS

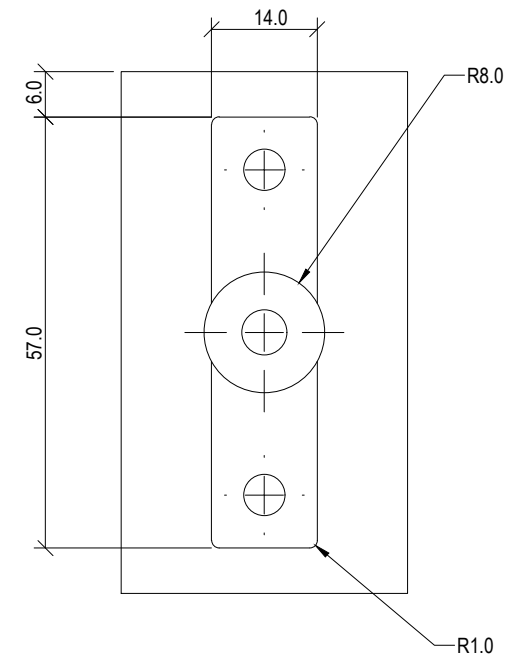
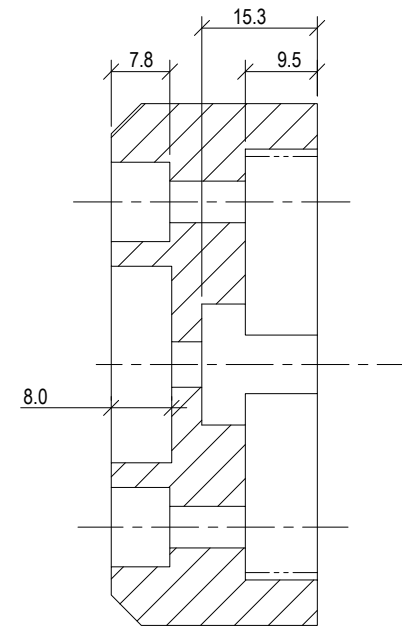
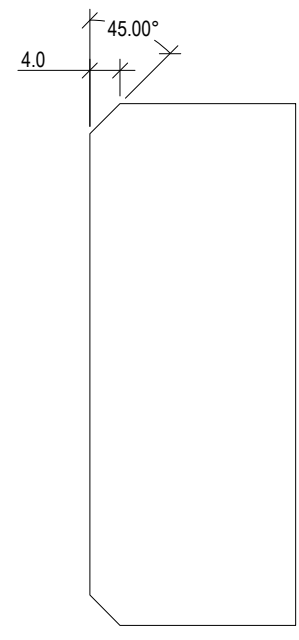
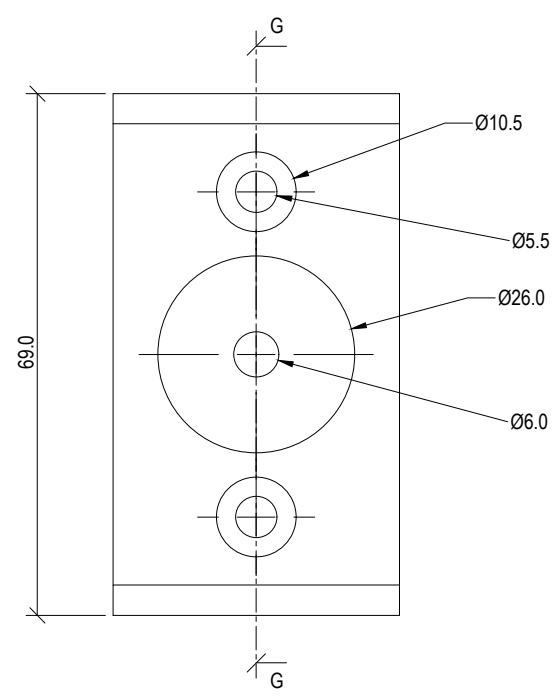
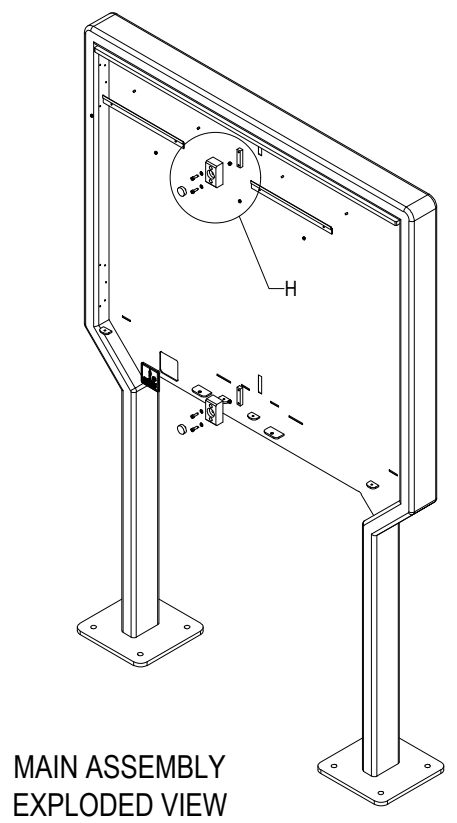

	BRISBANE CITY COUNCIL STANDARD DRAWING		PUBLISH DATE
	COMMUNITY NOTICE BOARD DOOR STOP BLOCK SHEET 6 OF 8		SCALE AS SHOWN
			DRAWING NUMBER BSD-7141
	ORIGINAL SIZE A3	REVISION A	